

LED PENDANT LIGHT



LGC SERIES



Key Features

- Complete solution with heat sink, driver and polycarbonate diffuser
- Vibration-resistant
- Alternative to 300W incandescent bulb
- Energy savings of up to 90% compared to 300W incandescent bulb
- Long service life of 30,000 hours L70 @ 45°C (Ta)
- Safety, EMC and IEC compliance

Application

Engine rooms, Low visibility areas, Decks, Warehouses, Yards

Material

Marine grade aluminium alloy with powder coating and PBT fiberglass reinforced body, polycarbonate diffuser and guard

Options

- Polycarbonate clear guard (PC)
- Polycarbonate red guard (PR)

Weight

1.5Kg

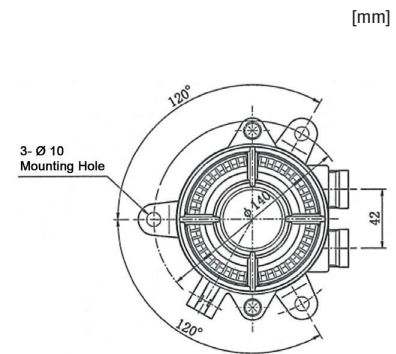
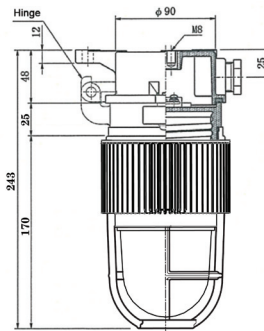
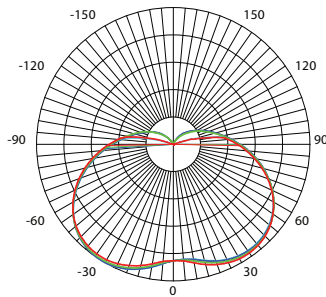

TECHNICAL SPECIFICATIONS

IP 56

- PC Denotes : Polycarbonate clear guard
- PR Denotes : Polycarbonate red guard

Ideal Replacement:



BH Code	Type	Main Voltage	Power	CCT	Beam Angle	Ambient Temp (Ta)	System Lumen
LGC30AD25KPC	LGC-30	100V - 240V AC/DC	30W	5000K	180°	-40°C ~ +45°C	2900lm
LGC30AD25KPR	LGC-30	100V - 240V AC/DC	30W	5000K	180°	-40°C ~ +45°C	2900lm

Also available in other CCT.